

Dedicated to improving vehicle fun, safety & performance

Installation Instructions

Poly Bushings for Front Suspension Control Arm Stay for 700 & 900 Series *ipd* #8K0058, 8K0059



SUGGESTED TOOLS

- Metric wrenches and socket

SAFETY WARNINGS



- Always support the vehicle with jack stands before working underneath
- Check ALL the fasteners for tightness before and after road testing the vehicle
- Do not use air impact wrench when re-installing bolts as stripped threads may result

INSTALLATION

- 1 Raise and support the vehicle with jack stands so that the front suspension can hang freely.
- 2 Remove the front bolt (A), large washer and old bushing from the control arm stay.
- 3 Remove the bolt holding the stay rear bushing to the car (B).
- 4 Remove the arm from the suspension.

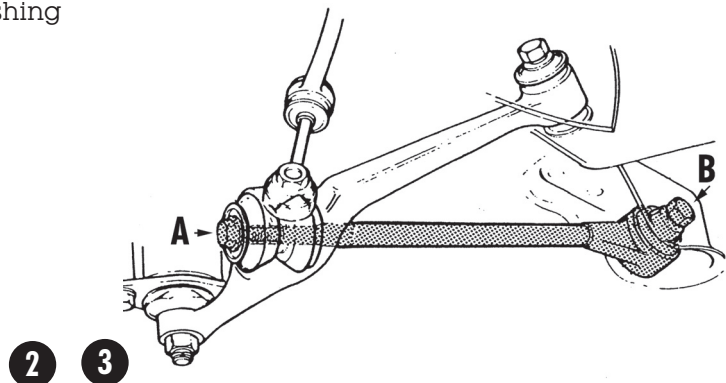

INSTALLATION

5 Remove the old cone shaped bushings from the front of the stay. Leave the large rear washer in place on the stay.

6 Put the spacer sleeve and one poly bushing in place on the stay.

7 Face the cone shape toward the control arm.

8 Replace the stay arm in place and attach with the old bolt through the rear bushing (B). Use some threadlock on the threads if desired.

9 Install another poly bushing in the front of the stay arm along with the washer and new bolt. Use threadlock on the new bolt.

10 Repeat procedure on the other side.

11 Perform final tightening of all bolts. This is best done with the car on the ground.

12 Test drive and recheck bolts for tightness.

